

1. SAFETY RULES

- This meter is designed for indoor use at temperatures between 0°C to 40°C and altitudes up to 2,000m.
- To ensure that the meter is used safely, follow all safety and operating instructions in this operation manual. If the meter is not used as described in this operation manual, the safety features of this meter might be impaired.
- Do not use the meter if the meter or test leads look damaged, or if you suspect that the meter is not operating properly.
- When using the instrument, keep your fingers behind the finger guards on the plastic casing and probes.
- Disconnect the live test lead before disconnecting the common test lead.
- Make sure power is off before cutting, desoldering, or breaking the circuit wires. Small amounts of current can be dangerous.
- Do not apply more than 600 VDC or 600V AC rms between a terminal and ground.
- To avoid electrical shock, use CAUTION when working above 60V DC or 25V AC rms. Such voltages pose a shock hazard.
- Never make measurements with the battery cover off.
- To avoid electrical shock or damage to the meter, do not exceed the input limits.

2. INTERNATIONAL SYMBOLS

- | | | | |
|--|----------------------------------|--|--------------------|
| | Important information see manual | | Dangerous Voltages |
| | AC | | Continuity |
| | DC | | Ground |
| | | | Double Insulation |

3. TECHNICAL SPECIFICATIONS

3.1 General Specifications

- | | |
|------------------------|---|
| Display: | 3-3/4 digits LCD, max. of 3999 display with decimal point and engineering units |
| Polarity: | Automatic, (-) negative polarity indication |
| Zero adjustment: | Automatic |
| Sample rate: | 0.5 Sec. |
| Over range indication: | reading "OL" is displayed |
| Power: | 9-volt battery type NEDA 1604, IEC6F22 |
| Battery life: | Approx. 50 hours. (w/ alkaline batteries) |
| Dimension: | 141 x 69 x 36 mm. |
| Weight: | Approx. 160g (including battery). |
| Accessories: | User's Manual, Alligator Clip, Probes Cups and 9V alkaline battery |

3.2 Electrical Specifications

- The mark next to the probe tip, is a warning that the input voltage should not exceed the indicated values. This is to prevent personal injuries and damage to the internal circuitry.
- The function switches should be set to the function which you want to test before operation.
- Accuracies are \pm (% of reading + number of least significant digits) at 23°C \pm 5°C, less than 75% RH.

Function	Range	Accuracy	Input Impedance	Remarks	Overload Protection
DC Voltage	4000mV, 60V 600V	0.8%+1	10 M Ω	-	600 Vp-p
AC Voltage	4000mV, 60V 600V	1.2%+3	10 M Ω	40~400Hz	600 Vp-p
DC Current	40 - 400 mA	1.2%+3	-	-	400 mA/ 250V Fuse
AC Current	40 - 400 mA	1.2%+5	-	40~400Hz	400 mA/ 250V Fuse

Function	Range	Accuracy	Input Impedance	Remarks	Overload Protection
Resistance	400 Ω , 4k Ω , 40k Ω ,400k Ω 4M Ω	1.0%+2	-	1.2 mA max. test current	250 Vp-p
	40 M Ω	1.5%+2	-	0.47 mA max. Test current	250 Vp-p
Diode Test	Test Current:1.0 \pm 0.6mA		Test Voltage: 3.2 V Max.		250 Vrms

4. OPERATION

4.1 Instrument Description

- 1) Case
- 2) 3-3/4 Digit LCD display
- 3) ON/OFF and Range switch
- 4) Function switch
- 5) Fixed test lead with probe
- 6) Fixed probe tip and fuse cap
- 7) Battery cover
- 8) Display hold push button (back of the unit)
- 9) Probes cups
- 10) Alligator clip

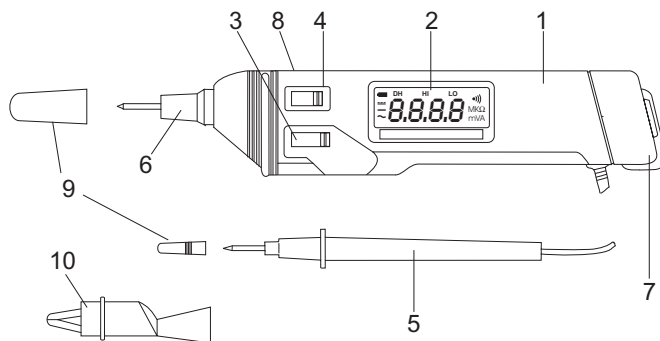

4.2 Display Description

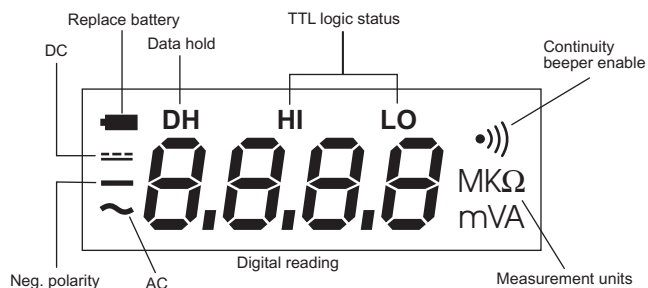

4.3 Measurement Procedures

CAUTION: Maximum Input Voltage is 600Vrms, do not exceed this rating to avoid personal injuries or damage to the instrument. The range FUNCTION/RANGE switch should be set to the range you want to test before the operation.

CAUTION: Always ensure that the correct terminals are used for the type of measurement to be made. Avoid making connections to "live" circuits whenever possible. When making current measurements ensure that the circuit is not "live" before opening it in order to connect the test leads.

4.3.1 DC Voltage measurement

- Set the **FUNCTION SWITCH** to “V” and the **RANGE SWITCH** to “DC/ Ω” function.
- Connect the test leads across the source or load under measurement.
- The measurement and polarity will be shown the LCD Display when the probes are connected.

4.3.2 AC Voltage measurement

- Set the **FUNCTION SWITCH** to “V” and the **RANGE SWITCH** to “AC/⊘)” function.
- Connect the test leads across the source or load under measurement.
- The measurement will be shown on the LCD Display when the probes are connected and current flows through the meter.

4.3.3 DC Current measurement

- Set the **FUNCTION SWITCH** to “A” and the **RANGE SWITCH** to “DC/ Ω” function.
- Connect the test leads in series with the source or circuit under measurement.
- The measurement and polarity will be shown the LCD Display when the probes are connected and current flows through the meter.

4.3.4 AC Current measurement

- Set the **FUNCTION SWITCH** to “A” and the **RANGE SWITCH** to “AC/⊘)” function.
- Connect the test leads in series with the source or load under measurement.
- The measurement will be shown on the LCD Display when the probes are connected and current flows through the meter.

4.3.5 Resistance measurement

CAUTION: Maximum Input Voltage for this function is 250 Vrms for less than 10 Sec., do not exceed this rating to avoid personal injuries or damage to the instrument. Also ensure there is no power applied to the component or circuit and all capacitors are discharged.

- Set the **FUNCTION SWITCH** to “R” and the **RANGE SWITCH** to “DC/ Ω” function.
- Connect the test leads across the component or circuit under measurement.
- The range will adjust automatically for optimal readout, and the measurement will be shown the LCD Display when the probe are connected.

4.4 Other Functions

CAUTION: Maximum Input Voltage for this function is 250 Vrms for less than 10 Sec., do not exceed this rating to avoid personal injuries or damage to the instrument. Also ensure there is no power applied to the diode.

4.4.1 Continuity Test

- Set the **FUNCTION SWITCH** to “R” and the **RANGE SWITCH** to “AC/⊘)” function.
- Connect the test leads across the circuit or component to test.
- Buzzer will sound if the circuit resistance is below 100Ω.

4.4.2 Logic Level Test

- Set the **FUNCTION SWITCH** to “TTL” and the **RANGE SWITCH** to “DC/ Ω” function.
- Connect the test leads across the source or circuit under test.
- The logic level will be shown as “HI” or “LO” on the LCD display according to the table below:

Input Voltage	TTL Logic Status	Display
Above 2.0 V	High	HI
Below 0.8 V	Low	LO
0.8 to 2.0 V	Undertermined	-
Negative input (-V)	Undertermined	HI/LO or LO/HI*
Pulse	Undertermined	HI/LO or LO/HI*

* The display will switch between HI and LO, but the response is affected by the pulses frequency

4.4.3 Display Hold

A push button switch at the back of the unit is used to hold display readings during measurements.

- Pressing the button holds the display reading, and “DH” appears on the display.
- Pressing the button again resumes normal operation.

4.4.4 Auto Power OFF

The meter will turn off automatically to extend the battery life after approx. 30 minutes without operating. To turn it on again, set the **FUNCTION SWITCH** to the “OFF” position and then to the desired range position.

5. MAINTENANCE

CAUTION: Before attempting battery removal or replacement, disconnect test leads and remove the instrument from any energized circuit to avoid shock hazard.

5.1 Battery Replacement

- When the battery needs replacement, the battery symbol  will appear in the lower left hand side of the LCD display.
- To replace the battery, remove the screw at the back **Battery Cover** and replace with a new 9 V alkaline battery type NEDA 1604 or IEC6F22, observing the polarity as indicated at the back of the case.
- Reinstall the battery cover and tighten the securing screw.

5.2 Fuse replacement

- To replace the internal fuse, turn the **Fuse Cap** counter clockwise, to release the Fuse Cap assembly.
- Take out the blown fuse and replace with a type IEC60127-2 or UL248-14 (5 x 20mm) fast acting fuse, rated at 400mA/250V.
- Replace the fuse cap, by inserting it in the meter body and turning the **Fuse Cap** assembly clockwise, until it locks.

5.3 Cleaning

Periodically wipe the case with a soft damp cloth and mild household cleanser. Do not use abrasives or solvents. Ensure that no water gets inside the instrument to prevent possible shorts and damage.

6. WARRANTY

One year limited warranty, excluding batteries and fuses. For details see Standard Warranty Information in our webpage or you may request a printed copy.

General Technologies Corp.	
#121 - 7350 72nd Street Delta, BC Canada V4G 1H9	Tel.: (604) 952-6699 Fax: (604) 952-6690 www.generaltechnologies.net